

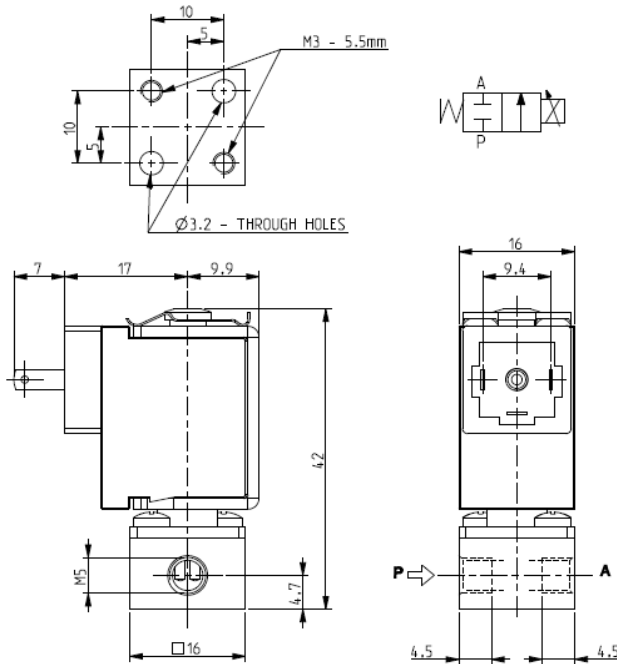

**MICRO SOLENOID VALVE**  
 2 ways - NC (Normally closed)  
 Direct acting  
**M5**

**V164**  
 PROPORTIONAL  
 FLOW CONTROL



► **GENERAL FEATURES**

Direct acting micro solenoid valve; minimum overall dimensions.  
 The flow rate is proportional to the input electric signal.  
 The chart overleaf shows an example curve of flow rate / electric signal at 3 bar inlet pressure.  
 Suitable to shut off liquid and gaseous fluids (verify the compatibility of fluid with materials in contact).

► **TECHNICAL FEATURES**

*Maximum allowable pressure (PS)* 16 bar  
*Fluid temperature* -10°C +90°C  
*Max viscosity* 3°E (~22 cStokes or mm<sup>2</sup>/s)

► **MATERIALS IN CONTACT WITH FLUID**

*Body* Brass  
*Sealing* NBR  
*Internal components* Stainless steel  
*Seat* Brass  
*Core tube* Stainless steel

► **COIL**

*Continuous duty* ED 100% (see note "A" overleaf)  
*Encapsulation material* PA (Polyamide) fiberglass reinforced  
*Insulation class* F (155°C)  
*Ambient temperature* -10°C +60°C  
*Electric connections* DIN 46340  
*Protection degree* IP 65 (EN 60529) with micro plug connector  
*Voltages DC* 12 - 24V

Port size ISO-UNI 4534	Orifice size (mm)	Inlet differential pressure (bar)		Kv (m <sup>3</sup> /h)	Series et type		Power absorption			Sealings	Notes	Weight (kg)
		Min	Max		Valve	Coil	AC (VA)		DC (W)			
							Inrush	Holding				
M5	1,6	0	5	0,04	V164B02	ZE30A	-	-	4	NBR	-	0,060

► **NOTES**

- These micro-solenoid valves are not suitable for stagnating media subject to vaporization which deposit solid, calcareous, incrusting residues or similar.
- Seal: NBR = Nitrile butylene elastomer
- Contact us for different pressure ratings and different proportionality features (flow rate / electric signal)

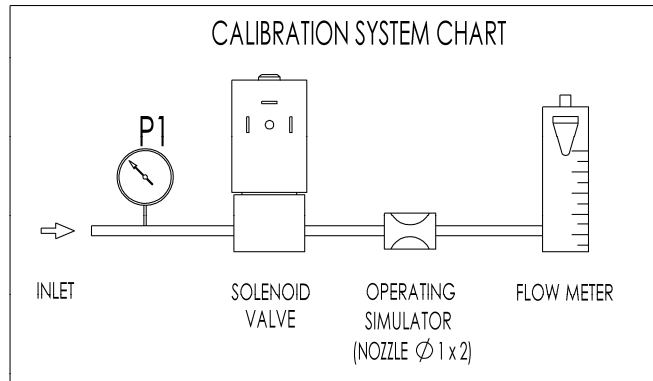

**V164B02 – ZE30A (orifice size=1.6mm)**  
CHARACTERISTIC CURVE AT INLET PRESSURE = **3 bar (dehumidified and non-lubricated air)**  
Reference coil 24V DC  
(See note "A")

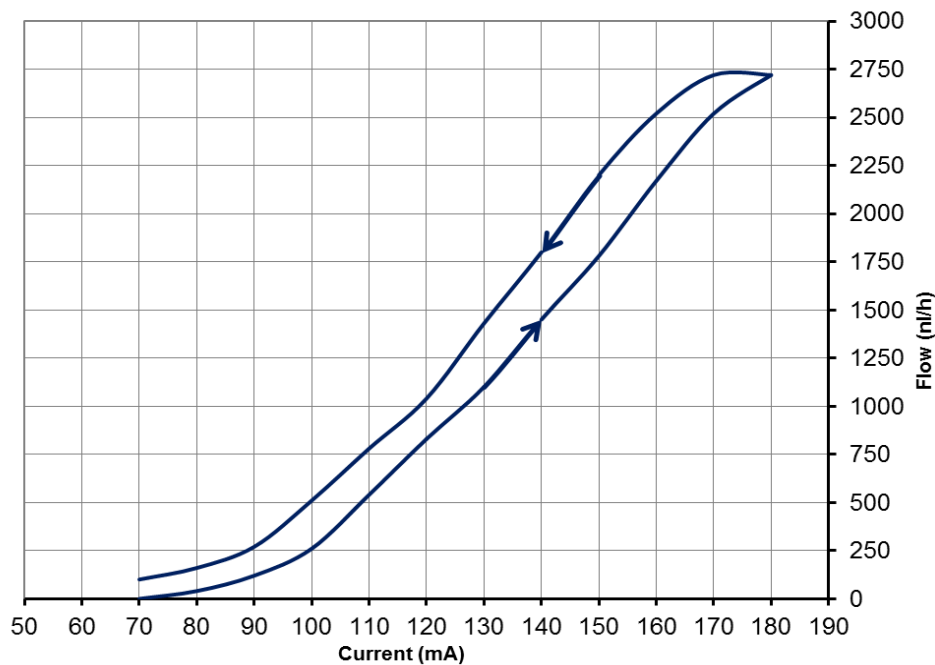

► **INSTALLATION**

Solenoid valve can be mounted in any position; vertical with coil upwards preferred.

► **NOTE "A"**

It is necessary to keep the current circulating in the coil constant so as to maintain the solenoid valve in any pre-determined position. In case the solenoid valve is energised by voltage variation, it has to be considered that the resistance of winding increases because of the continued energizing and consequently the power decreases. Therefore, it is necessary to compensate such power decrease by increasing the voltage to re-establish the initial current value.